

Education Quarterly Reviews

Al Jabri, A., Gangadharan, S., & Bendanillo G. (2022). Systematic Study of Student's Perception Towards Math through Teacher Related Dimensions: A Case of COTs in Oman. *Education Quarterly Reviews*, 5(3), 68-77.

ISSN 2621-5799

DOI: 10.31014/aior.1993.05.03.525

The online version of this article can be found at:
<https://www.asianinstituteofresearch.org/>

Published by:
The Asian Institute of Research

The *Education Quarterly Reviews* is an Open Access publication. It may be read, copied, and distributed free of charge according to the conditions of the Creative Commons Attribution 4.0 International license.

The Asian Institute of Research *Education Quarterly Reviews* is a peer-reviewed International Journal. The journal covers scholarly articles in the fields of education, linguistics, literature, educational theory, research, and methodologies, curriculum, elementary and secondary education, higher education, foreign language education, teaching and learning, teacher education, education of special groups, and other fields of study related to education. As the journal is Open Access, it ensures high visibility and the increase of citations for all research articles published. The *Education Quarterly Reviews* aims to facilitate scholarly work on recent theoretical and practical aspects of education.



ASIAN INSTITUTE OF RESEARCH
Connecting Scholars Worldwide

Systematic Study of Student's Perception Towards Math through Teacher-Related Dimensions: A Case of COTs in Oman

Amina Al Jabri¹, Shija Gangadharan², Glorigem Bendanillo³

^{1,2,3} UTAS Shinas, Sultanate of Oman

Abstract

Numerical explorations are accomplished to investigate the influence of student's perception towards Math which advances into academic dismissal in the preliminary level of higher education. The population under study are the students of seven Colleges of Technology across Oman. Data analyses were done using descriptive statistics of frequency counts and percentages obtained from the research questionnaire, while the hypothesis was tested using the statistical tools at 0.05 level of significance. This study examines the student's perception correlated with teacher-related factors. The structural equation modelling (SEM) is grounded on the three teacher-related dimensions that influence the student's perception towards Math namely 4 attributes relating to personality traits of lecturers, 6 attributes for teaching skills of the lecturer, and 2 attributes for instructional material used by the lecturers to impart the Basic Math needs for higher education. This analysis shows an overall reliability analysis for teacher-related dimensions to be 0.943 by applying Cronbach's alpha reliability test, and the SEM tool kit analysis of the model confirmed the hypothesis of the latent variables and the theoretical authenticity of the explored factors. The conclusions of this study might be useful to substantiate the importance of student evaluation on teachers done every semester and would be a component in reducing the dismissal of students at the initial stage of higher education in Oman.

Keywords: Structural Equation Modelling, Cronbach's Alpha Reliability Test, Perception Towards Math, Omani Education

1. Introduction

Education has always been the driving force that pushes every nation towards development, progress, and sustainability in a global arena. For this reason, every nation allots a huge budget to education to ensure its quality. In Oman, education is given for free for its citizens because the government believes that it has an obligation to provide the Omani youths with the opportunity to develop them with knowledge and skills so they can positively contribute to the society in the future. Educational institutions at different levels were established and built in the different regions of the sultanate to ensure everyone had access to education. For higher education, the government has put up seven (7) Colleges of Technology (CoTs) offering various degree programs in response to the demands and requirements of the labor market. The General Foundation Program (GFP) of the CoTs in Oman which includes Basic Math and IT for Foundation besides English courses are required to enter any degree programs.

These courses prepare the students with the basic skills relevant to the requirements of various higher education studies. However, for several students, Basic Math becomes a bottleneck for them to move forward on the educational ladder, and in worst cases if they are dismissed, it will impede them from pursuing any degree program. If several students are dismissed every semester year after year, in the long run the government may not be able to implement 100% “Omanization” in the different sectors in the country in the near future because of lack of qualified human resources and it will still depend on the technical and academic skills of expatriates.

General Foundation Program (GFP), in the Sultanate of Oman, is a non-credit program designed to provide academic assistance to students who have passed the required secondary education exit standards but have not yet succeeded in meeting the required academic standards of higher education (Carroll, Razvi, & Goodliffe, 2009). The program strengthens and enhances the students’ abilities in English, Mathematics (Sivaraman, Al Balushi, Rao & Rizwan, 2012), Information and Communications Technology (ICT) skills, and general academic and study skills, so that students (of GFP) are as competent as the direct entry students in higher education institutions (HEI). For years of GFP’s implementation in the seven (7) Colleges of Technology (CoTs) in the Sultanate, the program showed a positive impact on the academic successes of students in their higher education studies. However, there is now a growing concern regarding Student Dismissals due to the failure of passing Basic Math and IT for Foundation courses. This study aims to investigate the factors behind these failure cases due to Math courses to craft better policies and strategies to address this issue.

In a recent study in 2016 at one of the CoTs in Oman, poor academic performance of Omani students in the post-Foundation level (tertiary level) is associated with student-related factors, teacher-related factors, family-related factors, and other social and environmental contributing factors. The study showed that student-related factors have the greatest impact on student performance (Alami, 2016). And in a separate study, it is said that student motivations have a direct relationship with academic achievement (Martin, Galen-tino & Townsend, 2014; Coleman & McNeese, 2009) and thus, also have an implication in student’s poor performance which may lead to student failure. Parents and family are also critical in the student’s academic achievement (Coleman & McNeese, 2009; Wilder, 2014; Al-Mahrooqi, 2012). It is also noted that other social and environmental factors such as peers, socio-economic status (SES) and living conditions were found to be also a factor (Al-Mahrooqi, 2012).

Furthermore, numerous studies also show that there is a strong relationship between teacher quality and improvement in student learning (Ambussaidi and Yang, 2019; Hill, Rowan & Ball, 2005). In teaching mathematics, a study on the impact of mathematics teacher quality on student achievement in eight-grade math performance in Oman and Taiwan showed that there exists a relationship between teacher quality indicators and student achievement. However, the same study also mentioned that these variables which affect student achievement in both countries differ in the education context, characteristics of students, and school factors (Ambussaidi and Yang, 2019). In a similar study, Hill, Rowan, and Ball (2005) concluded that teachers’ mathematical knowledge has a significant relation to student achievement in first and third-grade students. The result was obtained through metrics that focus on content-specific mathematical knowledge and skills used in teaching mathematics. The finding supports initiatives to design policies that improve student math achievement by enhancing mathematical knowledge of teachers. The study proposed that programs that teach critical thinking and problem solving could be reinforced through focus on domain knowledge with strong emphasis on helping students understand the importance of how learning a new knowledge in various ways can affect their problem-solving abilities (Bransford, et al. 2004).

Moreover, Jurgen Baumert (2010), in a one-year study conducted in Germany with a typical sample of Grade 10 classes and their mathematics teachers, the study demonstrated that teacher’s pedagogical subject knowledge was theoretically and empirically discernable from their content knowledge. Multilevel structural equation models uncovered a significant optimistic effect of pedagogical content knowledge on student learning benefits that was facilitated by the supply of cognitive activation and individual learning support. Nor Fadilah et al. (2010) determine the criteria important in measuring attitude towards mathematics using factor analysis.

The focus of this study is to measure the student teacher dimensions to improve the learning traits of Omani students and in particular be a vital part in relaying the students to higher education. To the best of our knowledge

there is no article using the SEM analysis for demonstrating student perception towards Math correlated with teacher-related dimensions has been published for Omani students.

2. Methodology

This article uses a survey method to analyze students' perception towards Mathematics through teacher-related dimensions. A formal questionnaire was developed by the authors based on expert opinion, experience, and guided by related research. The survey forms were circulated among the students who studied Basic Math course at the foundation level in the Colleges of Technology in the Sultanate of Oman with 12 items to be ranked. The SEM analysis is employed to model the study and the outcome is predicted through confirmatory factor analysis (CFA). According to Hair et al. (2010), SEM analysis is acceptable for 150 participants for determining less than seven constructs and modest communalities.

2.1. Participants

The respondents are the students of the College of Technology (COT) who are dispersed in the different regions of Oman. It was shared to the students of the seven COT branches with the help of lecturers. A total of 1909 respondents' rankings were considered in this analysis. The following (see Table 1) shows the details of geographic dispersion of the respondents. The gender respondents' (see Table 1) progress has been casted in the education and interest of Omani students, which asserted how more of young female Omani population is dominating the education society.

2.2. Data Collection

The survey questionnaire with twelve items associated with teacher-related dimensions was set with experience in teaching and academic excellence. The response was gathered on a 5-point Likert scale with twelve items listed (see Table 2). Rating 1 is for strongly disagree, rating 2 is for disagree, rating 3 is for neutral, rating 4 is for agree and rating 5 is for strongly agree. The percentage method is used to present the data collected in the frequency distribution table for the descriptive analysis. The mean and variance of the Likert scale gathered from the respondents are shown in Table 3. None of the values of the mean is less than 3.0 so all the criterion is important and all these affect the respondent's perception towards Math related to teacher's dimensions. While the inferential statistics of confirmatory factor analysis and structural equational modeling were used in the prediction analysis of student's perception of Math correlated with teacher-related dimensions.

2.3. Hypothesis

The model demonstrated in this study spins around the following propositions. The depicted teacher dimensions with the items in the survey questionnaire are correlated in the hypothesis.

H1: Items 1-4 (MTSTa1-a4) will have a significant influence on the personality traits (F1) of the lecturer.

H2: Items 5-10 (MTSTb1-b6) will have remarkable influence on the teaching skills (F2) of the lecturer.

H3: Items 11-12 (MTSTc1-c2) will have a great impact on the instructional material (F3) used by the lecturer.

3. Findings

The outcomes of this research were largely built on the quantifiable data gathered from the respondents using the questionnaire developed by the authors based on the expert opinion and experience in teaching and academic excellence in the Sultanate of Oman. The study consists of 1909 respondents as samples.

For the 12 items assessed here (see Table 4), the total alpha was 0.943, which is Excellent. Thus, this demonstrates the model's internal consistency and dependability. According to Nunnally (1978), a model's minimum level of reliability is determined by how it is utilized. In a study by Lance et al. (2006), it implies that the requirement for any measurement scale to have a Cronbach's alpha value greater than 0.70 is a myth. In Table 4, the Cronbach's

alpha values for the subscales are: 0.9 to 1.0 is marvelous, 0.8 to 0.9 meritorious, 0.7 to 0.8 middling, 0.6 to 0.7 mediocre and 0.5 to 0.6 miserable (Kaiser & Rice, 1974).

The first step in SEM begins with the validation of measurement model using Confirmatory Factor Analysis (CFA) (see Figure 1).

3.1. Evaluating the Model fit Summary

The capacity of a model to recreate data (i.e., usually the variance-covariance matrix) is described to as fit. A good-fitting model is one that is sufficiently coherent with the data and hence doesn't need to be re-specified. Before interpreting and analyzing the structural model's causal paths, a good-fitting measurement model is necessary. The fit indices refer to the investigator about the model fit, and the fit indices from AMOS are indicated in the subsequent two tables (see Figure 1, Table 5). A set of several relationships is represented by various equations in SEM tests. The data obtained for the exploratory factor analysis disclosed that the factor loadings vary between 0.57 to 0.92. As a result, the fit must be determined for the entire model rather than for a particular relationship.

3.2. Decomposition of Covariance and Correlations

The 'Standardized Regression Weights' present the regression weights that would have appeared, had the measured variables first been transformed to z scores - by subtracting the mean and dividing up by the standard deviation.

The scales of these amounts are utilized to detect variables that are unrelated to the factors. Variables with regression weights less than 0.5 are not well matched with the factors. All of the measured variables are aligned with their appropriate factors, according to the table (see Table 6).

The CR stands for 'Critical Ratio,' which is equal to the regression weight divide up by its standard error. Because this ratio's distribution seems like a Z distribution, CR values greater than 2 are considered significant at 0.05 level. All the statistics in each latent variable are significant in the table (see Table 6) since the CR for the variables is more than 2.

3.3. Path Analysis for testing Structural Model

Path analysis is the second step of Structural Equation Modeling (SEM), the multivariate procedure that, as defined by Ullman & Bentler (2012), "allows inspection of a set of associations between one or more independent variables, either continuous or discrete, and one or more dependent variables, either continuous or discrete" (p. 661). In SEM, calculated and hidden variables are dealt. Additionally, multiple regression and factor analysis are combined in SEM. Moreover, path analysis deals with understanding structural relationship among the latent variables as identified in the confirmatory factor analysis. In Figure 2, the estimates of path analysis of the model are figured to understand the relationship among the teacher dimensions to math students on study related variables. This supports the analysis identified by CFA analysis.

Arrows in path language indicate hypothesized causal relationships. A one-headed arrow points from the cause (independent variable) to the result (dependent variable).

Hypothesis

H₀: The proposed model is a perfect fit for the study.

Disintegration of Correlations:

The unstandardized co-efficient estimates in Figure 2 explain the link between latent variables.

3.4. Structural equation modeling (SEM): Model fit assessment

Based on the obtained samples, structural equation modeling was performed to assess the model's appropriateness. As advised by Anderson & Gerbing (1988), the first step is to analyze the measurement model that is used to verify the survey instrument's reliability and validity, and then, analyze the structural model using AMOS version 18. When determining the causal relationship between variables and evaluating the model's compatibility, the structural equation model (SEM) is the most useful (Tobbin, 2011).

3.4. Significance tests of individual parameters

In the Table 7, the unstandardized coefficients and related test statistics are shown. The unstandardized regression coefficient represents the amount of change in the dependent or mediating variable for every unit change in the variable that predicts it. Moreover, Table 7 indicates the unstandardized estimate, its standard error (abbreviated S.E.), and the estimate divided by the standard error (abbreviated C.R. for Critical Ratio). While the probability value for the null hypothesis that the test is zero is displayed in the column P.

*** As a result, Chi square values with $p = 0.000$ do not indicate a good model fit. Nonetheless, a sample size of over 200 (1909 in this study) could impact Chi-Square statistics to imply a significant probability level ($p=0.00$), according to Schumacker & Lomax (1996).

Therefore, the goodness of fit measures can then be used to further interpret this model. Structural equation modeling determines whether the data fits a theoretical model (see Table 8). As shown in Table 8, the CFI, GFI, AGFI, IFI, and RMSEA were used to evaluate the model. The measurement model fit was estimated using common model-fit measures such as the comparative fit index (CFI), root mean square error of approximation (RMSEA), normed fit index (NFI), and incremental fit index (IFI). The model fit indices estimate from AMOS structural modeling are shown in the Table 8.

The following are the criteria for an appropriate model, according to Gerbing & Anderson (1992): RMSEA of 0.08 or less, CFI of 0.90 or more, and NFI of 0.90 or more. A chi-square goodness-to-fit (GFI) test can be used to assess the fit between the data and the suggested measurement model, with a probability of greater than or equal to 0.9 indicating a good fit (Hu and Bentler, 1999). The GFI in this study was 0.964, which is greater than 0.9, and the other metrics fit well: AGFI=0.932, CFI=0.977, IFI=0.978, NFI=0.975, and RMSEA=0.063 (Bagozzi & Yi, 1988). The model fit is supported by goodness of fit indices, and these highlighted indices demonstrate that the structural model fit is excellent.

4. Conclusion

This article reviews the teacher-related dimensions of the student's perception towards Math. It was concluded with the structural equation modelling analysis that there is a significant influence between the student's perception of the teacher-related dimensions towards Math. This shows the extent to which the proposed model analysis supports the already existing theory with the relationship among the variables considered in this article supported by the empirical data. The CFA and the path analysis helps teachers to measure the different dimensions to support the students in reducing the dismissal and improving the skills for higher education. Our research suggests the importance of teacher dimension i.e the personality traits, teaching skills and the instructional materials used in the class by the teachers play a significant role in building up the confidence level in the course. Among the three dimensions the teaching skills have a remarkable influence on students' perception, so the teacher's strategies which are based on their skills have the greatest impact on building up interests in students. Hence, it is also very important for the student to build a good rapport with teachers to develop their interest in the study of Math courses for their overall development into their alleyway to higher education. We see that teacher dimensions greatly influence the student's perception towards Math. This research work would be of great importance for the teachers, education directors, scholars, strategy creators, parents and stakeholder as well to build strategies that improve the teacher-related dimensions to achieve good relations with students to improve Math education.

4.3. Figures and Tables

Table 1: Data Presentation of the Respondents.

Variable	Frequency	Percentage
Geographic Dispersion		
Al Musanna	12	0.7%
Ibra	90	5%
Ibri	55	3%
Muscat	22	1%
Nizwa	75	4%
Salalah	6	0.3%
Shinas	1649	86%
Total	1909	100%
Gender		
Female	1095	57%
Male	814	43%
Total	1909	100%

Table 2: Teacher-related Factors' Dimensions.

ITEMS	Measurement	Item Name	Dimensions
1	The lecturer has a good relationship (establishes good	MTSTa1	Personality traits of lectures (F1)
2	and firm in making decisions.	MTSTa2	
3	The lecturer imposes proper discipline and not lenient in	MTSTa3	
4	The lecturer is open to suggestions and opinions.	MTSTa4	
5	The lecturer explains the objectives of the lesson clearly at the start of	MTSTb1	Teaching skills (F2)
6	The lecturer shows mastery of the subject matter.	MTSTb2	
7	The lecturer is organized in presenting the subject matter by	MTSTb3	
8	The lecturer uses various strategies, teaching aids/devices	MTSTb4	
9	The lecturer speaks clear English and his/her instructions are	MTSTb5	
10	The lecturer prepares well thought-out, valid and reliable assessments.	MTSTb6	
11	The lecturer uses various kinds of instructional materials such as	MTSTc1	Instruction materials (F3)
12	The lecturer designs the instructional materials easy to	MTSTc2	

Table 3. Mean and Variance of the Teacher-related Dimensions.

Dimension	Item Name	Mean	Variance	Mean per Dimension	Variance per Dimension
F1	MTSTa1	4.01	0.83	3.93	0.88
	MTSTa2	3.94	0.87		
	MTSTa3	3.81	0.88		

	MTSTa4	3.97	0.94		
F2	MTSTb1	4.00	0.86	3.88	0.91
	MTSTb2	3.93	0.85		
	MTSTb3	4.06	0.75		
	MTSTb4	3.65	1.08		
	MTSTb5	3.72	1.14		
	MTSTb6	3.92	0.79		
F3	MTSTc1	3.72	1.06	3.76	1.00
	MTSTc2	3.79	0.94		

Table 4: Result of reliability analysis for Teachers related factors dimensions.

Dimensions	Number of attributes	Cronbach's alpha
Personality traits of lectures	4	0.845
Teaching Skills	6	0.913
Instruction Material	2	0.807
Overall reliability analysis for TEACHERS RELATED dimensions	Cronbach's alpha	0.943
	No. of Items	12

Table 5: Chi-Square and Standardized RMR.

Computation of degrees of freedom	
Number of distinct sample moments	78
Number of distinct parameters to be estimated	29
Degrees of freedom (78-29)	49
Chi-square and Standardized RMR	
Chi-square	418.669
Degrees of freedom	49
Probability level	.000

Source: Primary data. Results computed by the package – AMOS

Table 6: Standardize Regression Weights.

Maximum Likelihood Estimates - Regression Weights							
Variables/Indicators			Regression Weights				Standardized Regression Weights
			Estimate	S.E	C.R.	P	Estimate
MTSTa4	<---	F1	1.000				.834
MTSTa3	<---	F1	.688	.027	25.654	***	.663
MTSTa2	<---	F1	1.023	.024	42.431	***	.868
MTSTa1	<---	F1	.960	.024	40.097	***	.820
MTSTb5	<---	F2	1.000				.848

Maximum Likelihood Estimates - Regression Weights							
MTSTb4	<---	F2	.915	.027	34.401	***	.811
MTSTb3	<---	F2	.843	.022	38.909	***	.817
MTSTb2	<---	F2	.942	.023	41.456	***	.828
MTSTb1	<---	F2	.906	.023	39.199	***	.870
MTSTc2	<---	F3	1.000				.852
MTSTc1	<---	F3	.908	.024	37.519	***	.894
MTSTb6	<---	F2	.882	.022	40.015	***	.789

Source: Primary data. Results calculated by the package – AMOS *** - p- value less than 0.001

Table 7: Significance Test.

Path coefficients in SEM							
Variables/Indicators			Unstandardized co-efficient		C.R	P	Standardized Regression Weights
			Estimate	S.E.			
F1	<---	F3	.729	.024	30.835	***	.809
F2	<---	F3	.415	.030	13.892	***	.429
F2	<---	F1	.617	.034	18.305	***	.575
MTSTa4	<---	F1	1.000				.804
MTSTa3	<---	F1	.687	.027	25.596	***	.571
MTSTa2	<---	F1	1.025	.024	42.400	***	.856
MTSTa1	<---	F1	.962	.024	40.105	***	.820
MTSTb5	<---	F2	1.000				.783
MTSTb4	<---	F2	.903	.026	34.119	***	.728
MTSTb3	<---	F2	.826	.022	38.163	***	.798
MTSTb2	<---	F2	.926	.023	40.884	***	.841
MTSTb1	<---	F2	.901	.023	39.267	***	.814
MTSTc2	<---	F3	1.000				.889
MTSTc1	<---	F3	.887	.024	36.384	***	.747
MTSTb6	<---	F2	.880	.022	40.313	***	.830

Source: Primary data. Results calculated by the package – AMOS

Table 8: Fit indices of measurement models.

Measure	Estimate	Threshold	Interpretation
CMIN	348.976	--	--
DF	51	--	--
CMIN/DF	6.843	--	***
CFI	0.977	>0.90(Hu & Bentler, 1999)	EXCELLENT
GFI	0.964	>0.90 (Hair et al., 2006)	EXCELLENT

AGFI	0.932	>0.90 (Hooper et al., 2008)	GOOD FIT
NFI	0.975	>0.90 (Hu & Bentler, 1999)	EXCELLENT
IFI	0.978	>0.90 Approaches 1	EXCELLENT
SRMR	0.019	<0.08 (Hair et al., 2006)	EXCELLENT
RMSEA	0.063	0.05 - 0.10 (Hair et al., 2006)	GOOD FIT
Results for Default model compared with the Standards			
Source: Primary data. Results computed by the package – AMOS			

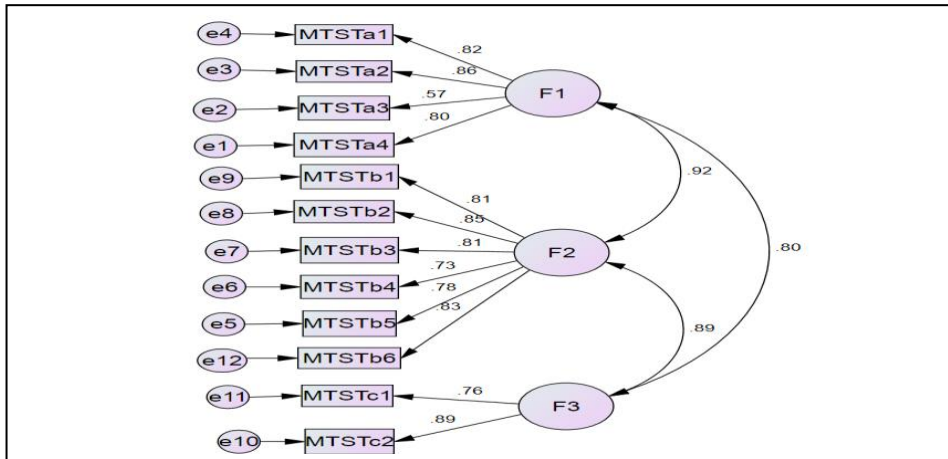

Figure 1: Confirmatory Factor Analysis for Teachers related Dimension by Math students.

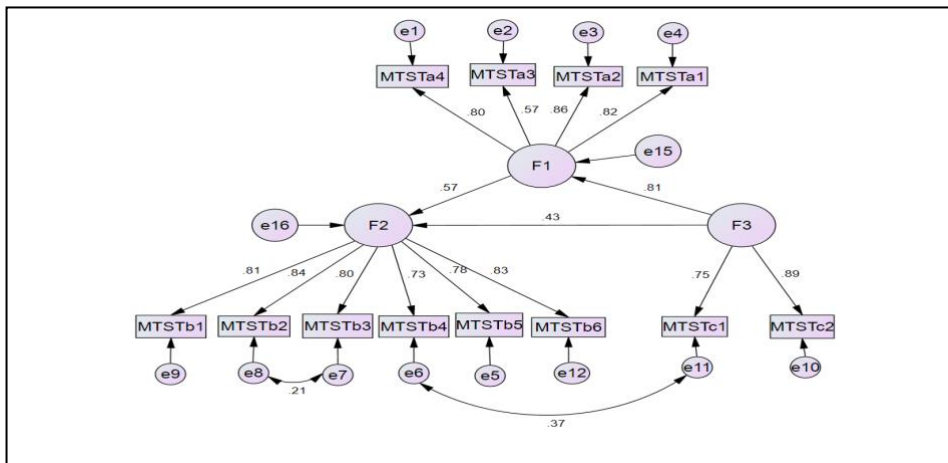

Figure 2: Path Diagram for Structural Model Showing Unstandardized Estimates of Factors Contributing to Math Students on Study Related Variable.

Acknowledgements

The authors would like to thank TRC Oman for supporting this research under GRG funding with Project ID: BFP/GRG/EHR/20/120 from 01/11/2020 to 31/10/2022 -TRL: 1-3: Knowledge Development.

References

Carroll, M., Razvi, S. & Goodliffe, T. Using Foundation Program Academic Standards as a Quality Enhancement Tool. 2009 International Network for Quality Assurance Agencies in Higher Education (INQAAHE), 2009.

Sivaraman, I., Hassan Mohammed Al Balushi, A., Rao, D. H., & Rizwan, S. M., “Entry into Engineering Programs – Performance Comparison of Foundation Students with Direct Entry Students.” 7, 2012.

Alami, M., “Causes of Poor Academic Performance among Omani Students. International Journal of Social Science Research”, 4(1), 126–136, 2016. <https://doi.org/10.5296/ijssr.v4i1.8948>

- Martin, K., Galentino, R., & Townsend, L. "Community College Student Success: The Role of Motivation and Self-Empowerment". *Community College Review*, 42(3), 221–241, 2014. <https://doi.org/10.1177/0091552114528972>
- Coleman, B., & McNeese, M. N. "From home to school: The relationship among parental involvement, student motivation, and academic achievement". 16, 459–470, 2009.
- Wilder, S., "Effects of parental involvement on academic achievement: A meta-synthesis". *Educational Review*, <https://doi.org/10.1080/00131911.2013.780009>, 66(3), 377–397, 2014.
- Al-Mahrooqi, R., "A Student Perspective on Low English Proficiency in Oman. *International Education Studies*", 5(6), 263–271, 2012.
- Ambussaidi, Intisar & Yang, Ya-Fei. (2019). The Impact of Mathematics Teacher Quality on Student Achievement in Oman and Taiwan. *International Journal of Education and Learning*. 1. 50-62. 10.31763/ijelev.v1i2.39.
- Hill, H. C., Rowan, B., & Ball, D. L. "Effects of Teachers' Mathematical Knowledge for Teaching on Student Achievement". 36, 2005.
- Jürgen Baumert, Mareike Kunter, Werner Blum, Martin Brunner, Thamar Voss, Alexander Jordan, Uta Klusmann, Stefan Krauss, Michael Neubrand, Yi-Miau Tsai, "Teachers' Mathematical Knowledge, Cognitive Activation in the Classroom, and Student Progress", 2010.
- Hair, J. F., Black, B., Babin, B., Anderson, R. E., & Tatham, R. L. *Multivariate Data Analysis*, 6th Edition (6th ed.), 2006. Pearson Prentice Hall.
- Nunnally, J. C. *Psychometric Theory* (2nd ed.), 1978. McGraw-Hill.
- Lance, C. E., Butts, M. M., & Michels, L. C. The Sources of Four Commonly Reported Cutoff Criteria: What Did They Really Say? *Organizational Research Methods*, 9(2), 202–220, 2006. <https://doi.org/10.1177/1094428105284919>
- Kaiser, H. F., & Rice, J. Little Jiffy, Mark Iv. *Educational and Psychological Measurement*, 34(1), 111–117, 1974. <https://doi.org/10.1177/001316447403400115>
- Ullman, J. B., & Bentler, P. M. (2012). *Structural Equation Modeling*. In *Handbook of psychology*, Second Edition. John Wiley & Sons, Ltd., 2012.
- Anderson, J. C., & Gerbing, D. W. Structural equation modeling in practice: A review and recommended two-step approach. *Psychological Bulletin*, 103(3), 411–423, 1988. <https://doi.org/10.1037/0033-2909.103.3.411>
- Tobbin, P. Adoption of Mobile Money Transfer Technology: Structural Equation Modeling Approach. *European Journal of Business and Management*, 3(7), 65, 2011.
- Schumacker, R. E., & Lomax, R. G. *A beginner's guide to structural equation modeling* (pp. xvi, 288), 1996. Lawrence Erlbaum Associates, Inc.
- Gerbing, D. W., & Anderson, J. C. Monte Carlo Evaluations of Goodness of Fit Indices for Structural Equation Models. *Sociological Methods & Research*, 21(2), 132–160, 1992.
- Hu, L., & Bentler, P. M. Cutoff criteria for fit indexes in covariance structure analysis: Conventional criteria versus new alternatives. *Structural Equation Modeling: A Multidisciplinary Journal*, 6(1), 1–55, 1999. <https://doi.org/10.1080/10705519909540118>
- Bagozzi, R. P., & Yi, Y. On the evaluation of structural equation models. *Journal of the Academy of Marketing Science*, 16(1), 74–94, 1988. <https://doi.org/10.1007/BF02723327>
- Hooper, D., Coughlan, J., & Mullen, M. *Structural Equation Modelling: Guidelines for Determining Model Fit*. *Articles*, 2008. <https://doi.org/10.21427/D7CF7R>
- Nor Fadilah Tahar, Zuriati Ismail, Nur Diana Zamani, Norshaieda Adnan, (2010). Students' Attitude Toward Mathematics: The Use of Factor Analysis in Determining the Criteria, *Procedia - Social and Behavioral Sciences*, 8, 476-481, 2010. ISSN 1877-0428.
- Aziz, S. M., Dimensions of IT literacy in an Arab region: A study in Barkha (Oman). 2009 *International Conference on Information and Communication Technologies and Development (ICTD)*, 288–299, 2009. <https://doi.org/10.1109/ICTD.2009.5426675>
- Bransford, J. D., Brown, A. L., Cocking, R. R., Donovan, M. S., & Pellegrino, J. W. *How People Learn*. Washington, D.C.: National Academy Press, 2004.
- Mallet, D. G. "Walking a Mile in Their Shoes: Non-Native English", *Speakers' Difficulties in English Language Mathematics Classrooms*. *Journal of Learning Design*, 4(3), 28–34, 2011.
- Neville-Barton, Pip, Bill Barton, Bill., "The Relationship between English Language and Mathematics Learning for Non-native Speaker". New Zealand, Wellington, 2005.
- Sergon, V. "Playing the Blame Game: English Education in Omani Government Schools". 37, 2011.